



JETS Challenge 109

Sponsored by



On the Radio

The WBMS radio transmitter is on top of a tower at a height of $H = 200\text{ft}$. It is supported by three sets of four guy wires each on 120° spacing around the base. Each set consists of 4 wires attached to the tower at equal spacing. The top two wires connect to a common anchor located $3H/4$ distance from the tower. The bottom two wires connect to a common anchor located $H/4$ away from the tower.

The Challenge: How many feet of cable are required to support this tower?

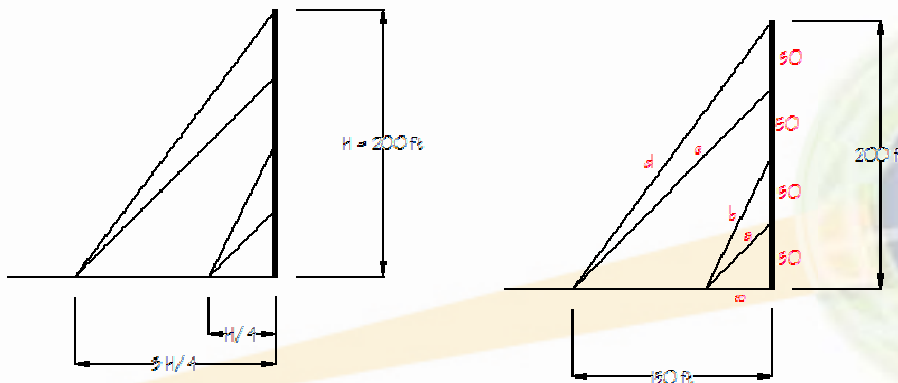

$H = 200 \text{ ft}$			
$H/4 = 50 \text{ ft}$			
$3H/4 = 150 \text{ ft}$			
$a^2 = 50^2 + 50^2$	$b^2 = 50^2 + 100^2$	$c^2 = 150^2 + 150^2$	$d^2 = 150^2 + 200^2$
$a = 70.710678 \text{ ft}$	$b = 111.803399 \text{ ft}$	$c = 212.132034 \text{ ft}$	$d = 250 \text{ ft}$
Length for 1 set = $a+b+c+d = 644.646111$		Length for 3 sets = 1933.9 ft	

ANSWER:



Explore... Assess... Experience Engineering!
www.jets.org